

TP-5

User's Manual

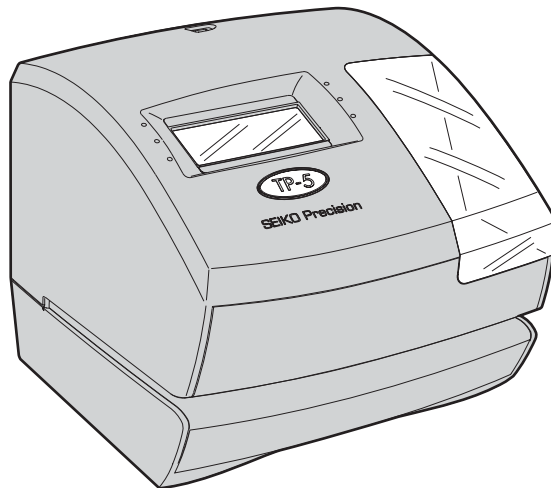

SEIKO Precision

TIMETEK SYSTEMS □
1300 669 630 □
sales@timetek.com.au

This unit complies with the Low Voltage Directive 73/23/EEC and the EMC Directive 89/336/EEC.

1. The details of this User's Manual are subject to change even without previous notification.
2. This User's Manual has been prepared with the utmost care to cover all aspects of the time clock's use.
3. Be sure to use your time clock after you have fully understood the hardware and software specifications and limits.
4. No part of this publication may be reproduced, stored in a retrieval system, or transmitted, in any form or by any means, mechanical, photocopying, recording or otherwise.



ALL RIGHTS RESERVED
©2005 SEIKO PRECISION INC.





Precautions







This user's manual is prepared for safe and proper use of the unit. Please follow all the instructions to avoid possible danger to yourself or others and damage to the unit.



Signs

Various warnings and cautions are provided throughout this manual along with signs. Remember each sign and its explanation listed below for your safety and proper operation of the unit.











	Warning	Improper handling may cause bodily accidents including death and serious injury.
	Caution	Improper handling may harm the human body or material.

	Improper handling may cause electric shock DANGER.		"Must-Do" sign.
	DO NOT disassemble the unit.		Be sure to remove the power plug from the outlet.
	"Don't" sign.		

 Warning	
	Do not disassemble the unit. There is a high voltage present inside, possibly leading to an electric shock.
	Do not modify the unit. Modifications may cause a fire and/or electric shock.
	If any anomaly occurs, for example, heat or smoke is generated or an odor is emitted, unplug the unit immediately and contact your dealer for servicing. There is a danger that further use may cause a fire or electric shock.
	Do not use any voltage of the power source other than designated. Do not share a single outlet with another plug. These may lead to fire or shock hazards.
	Do not damage, break, or modify the power cord. Do not put a heavy object on, pull, or forcefully bend the cord, either. These may damage the cord, possibly resulting in a fire or electric shock.

-  If foreign matter should get in the unit (including a piece of metal, water, or liquid), disconnect the plug from the outlet immediately and contact your dealer for servicing. There is a danger that further use may cause a fire or electric shock.
-  Do not plug or unplug the unit with a wet hand. You may get an electric shock.

 **Caution**

-  Do not place the unit on an uneven or tilted surface. This may result in injuries due to the unit dropping or falling off.
-  Do not put a water-filled container or a metal object on top of the unit. If water is spilled or the metallic object slips inside, a fire or shock hazard may occur.
-  Do not install the unit in a humid or dusty environment. It may cause a fire or electric shock.
-  Do not place the unit near kitchen counter or humidifier. Oil, smoke, or steam generating from them may cause fire or shock hazards.
-  Do not yank the power cord to disconnect from the outlet. Hold the plug with your hand to do so, or the cord may be damaged, possibly leading to a fire or electric shock.
-  Remove the power plug from the outlet before transferring the unit, or it may damage the cord, possibly leading to a fire or electric shock.
-  Be careful not to contact the print head, as you may get hurt or burned.
-  Make sure to insert the power plug as far as it will go. Improper insertion of the plug may develop fire or shock hazards.
-  Do not insert or drop any other time card than specified into the slot. Such misuse may cause a fire or electric shock.
-  If the unit should be dropped or the case be broken, unplug the unit and contact your dealer for servicing. Further use may lead to a fire or shock hazard.



Daily Care
 For cleaning, turn the power off and wipe the case clean of dust and dirt with a dry cloth, etc.



Vorsichtsmassnahmen







Dieses Bedienerhandbuch stellt die sichere und ordnungsgemäße Verwendung des Geräts sicher. Befolgen der Anweisungen schützt den Bediener und andere vor Verletzungen und verhindert die Beschädigung des Geräts.



Warnschilder

Nachfolgend werden Schilder mit Warn- und Vorsichtshinweisen dargestellt. Um das Gerät sicher und ordnungsgemäß handhaben zu können, hat sich der Bediener jedes Schild und die nachstehende Erklärung zu beachten.

	Achtung	Unangebrachte Handhabung kann zu Unfällen mit ernststen und tödlichen Körperverletzungen führen.
	Vorsicht	Unangebrachte Handhabung kann zu Körperverletzungen oder Sachschäden führen.

	Unangebrachte Handhabung kann zu GEFAHREN wie elektrischen Schlag führen.		Das Schild weist auf unbedingt erforderliche Handlungen hin.
	Das Gerät NICHT auseinandernehmen.		Den Stecker des Anschlußkabels aus der Netzsteckdose ziehen.
	Das Schild weist auf zu unterlassende Handlungen hin.		

 Achtung	
	Das Gerät nicht auseinandernehmen. Die hohe Spannung im Gehäuse könnte zu einem elektrischen Schlag führen.
	Das Gerät nicht umbauen. Änderungen könnten ein Feuer verursachen und/oder zu einem elektrischen Schlag führen.
	Tritt ein abnormaler Zustand ein, das Gerät wird z.B. heiß, raucht oder ein Geruch macht sich bemerkbar, sofort den Stecker aus der Netzsteckdose ziehen und den Kundendienst des Händlers benachrichtigen. Die weitere Verwendung könnte ein Feuer verursachen oder zu einem elektrischen Schlag führen.
	Das Gerät nur an eine Stromquelle mit der vorgeschriebenen Spannung anschließen. Anschluss von zwei Geräten an eine Netzsteckdose vermeiden, da dies ein Feuer verursachen oder zu einem elektrischen Schlag führen könnte.
	Das Anschlusskabel vor Beschädigung oder Bruch schützen und auf keine Weise ändern. Ferner keine schweren Gegenstände auf das Kabel stellen und jegliches ziehen oder knicken des Kabels unterlassen. Das Kabel wird dadurch beschädigt und könnte ein Feuer verursachen oder zu einem elektrischen Schlag führen.

	Geraten Fremdkörper (einschließlich Metallstücke, Wasser oder sonstige Flüssigkeiten) in das Gerät, sofort den Stecker aus der Netzsteckdose ziehen und den Kundendienst des Händlers benachrichtigen. Die weitere Verwendung könnte ein Feuer verursachen oder zu einem elektrischen Schlag führen.
	Den Stecker des Geräts nicht mit nassen Händen in die Netzsteckdose einstecken bzw. herausziehen, da dies zu einem elektrischen Schlag führen könnte.

 Vorsicht	
	Das Gerät nicht auf eine unebene oder schräge Oberfläche zu stellen. Das Gerät könnte nach unten rutschen bzw. fallen und zu Verletzungen führen.
	Die Oberfläche des Geräts nicht zum Abstellen von Wasserbehältern oder Metallgegenständen verwenden. Wenn verschüttetes Wasser eindringt oder ein Metallgegenstand in das Gerät fällt, kann dies ein Feuer verursachen oder zu einem elektrischen Schlag führen.
	Das Gerät nicht in einer feuchten oder staubigen Umgebung installieren, da dies ein Feuer verursachen oder zu einem elektrischen Schlag führen könnte.
	Das Gerät nicht in der Nähe einer Küchenanrichte oder eines Befeuchters installieren. Das dort vorhandene bzw. erzeugte Öl, Rauch oder Dampf kann ein Feuer verursachen oder zu einem elektrischen Schlag führen.
	Das Anschlusskabel nicht mit Gewalt aus der Steckdose ziehen, sondern mit der Hand entfernen. Beschädigung des Kabels könnte ein Feuer verursachen oder zu einem elektrischen Schlag führen.
	Bei Umstellen des Geräts den Stecker des Anschlusskabels aus der Netzsteckdose ziehen. Beschädigung des Kabels könnte ein Feuer verursachen oder zu einem elektrischen Schlag führen.
	Berühren des Druckkopfes vermeiden, da dies zu Verletzungen oder Verbrennungen führen könnte.
	Den Netzstecker ganz einstecken. Unangebrachtes Einstecken des Netzsteckers kann ein Feuer verursachen oder zu einem elektrischen Schlag führen.
	Nur die vorgeschriebenen Stempelkarten verwenden. Die Verwendung unangebrachter Karten kann ein Feuer verursachen oder zu einem elektrischen Schlag führen.
	Fällt das Gerät oder wird das Gehäuse beschädigt, den Netzstecker herausziehen und den Kundendienst des Händlers benachrichtigen. Die weitere Verwendung könnte ein Feuer verursachen oder zu einem elektrischen Schlag führen.

Tägliche Pflege

Das Gerät ist bei der Reinigung abzuschalten und mit einem trockenen Tuch von Staub und Schmutz zu befreien.

Thank you for purchasing our time clock.
For safe and proper operation, please carefully read the manual
before using the time clock and save it for reference.

Features:

Main applications: Payroll/job cost recorder or time stamp

- Quartz time clock
 - Dot matrix printer
 - Perpetual calendar
 - Automatic daylight saving time
 - 3-way print activation
 - Automatic
 - Semi-automatic
 - Manual
 - Prints in 4 languages
- 12 or 24-hour format
 - Regular minute, 1/10, 1/100
or 5/100 of an hour
 - 2 or 4-digit year imprint
 - 13 preprogrammed comments
 - Digital LCD display (Date, Hour,
Minute, Day of the week indication)
 - Adjustable print position
 - Prints seconds

Caution:

Avoid placing the unit in environments that are:

- humid or dusty.
- exposed to direct sunshine.
- subject to frequent or continuous vibrations.
- outside the temperature range between -5°C and 45°C
($+23^{\circ}\text{F}$ and 113°F).
- affected by chemicals or ozone.

Place the time clock close to the wall outlet so that it is easily
accessible to disconnect.

Do not put a heavy object on the clock, or not forcefully press the
cover of the clock. It may cause mechanism trouble and danger
especially when the unit is hung on the wall.

BEFORE USING THE TIME CLOCK

Accessories

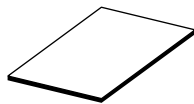

User's manual



Key

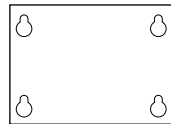

Wall-mount fittings
Screws (2 pcs.)
Template

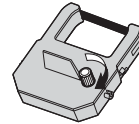

Ribbon cassette
(installed at the factory)

Configuration

<Front view>

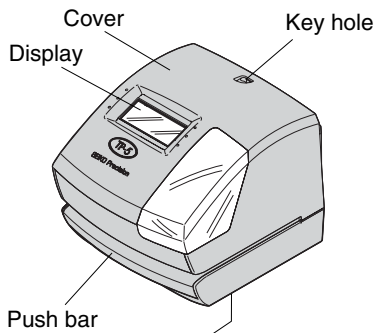

<Cover off>

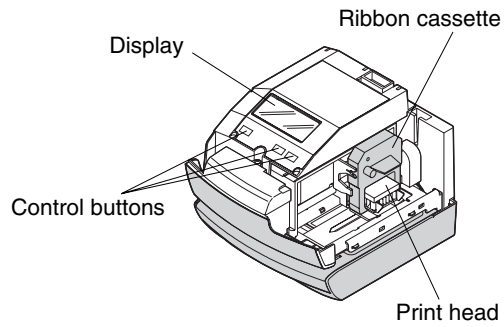

<Back view>

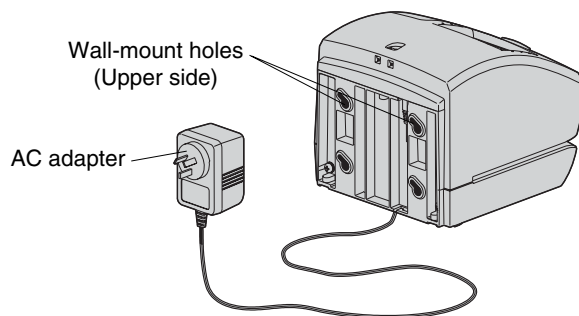

<Print position adjuster>

The print position from the card edge is adjustable by pressing and sliding the print position button on outside bottom.

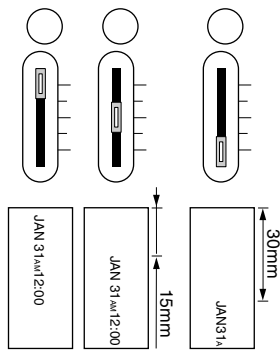

PRINT POSITION ON TIME CARD

The print position from the card edge is adjustable by pressing and sliding the print position button located on the right outside bottom of the recorder. Maximum distance from edge of form to print is approximately 1 3/16"(30mm).

QUICK EASY SETUP

NOTICE: Remove the **PROTECTION PAD** before you plug the AC adapter into the AC outlet.

To setup your time clock, follow next steps:

Step 1

Unlock the key and remove the cover.

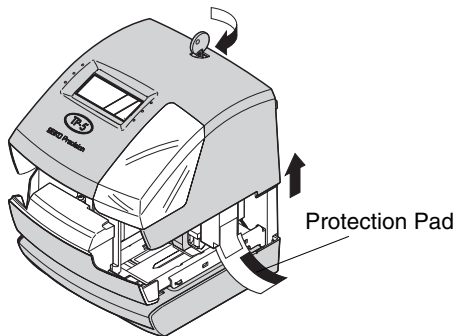

Step 2

Remove the **PROTECTION PAD**, and plug the AC adapter into the time clock.

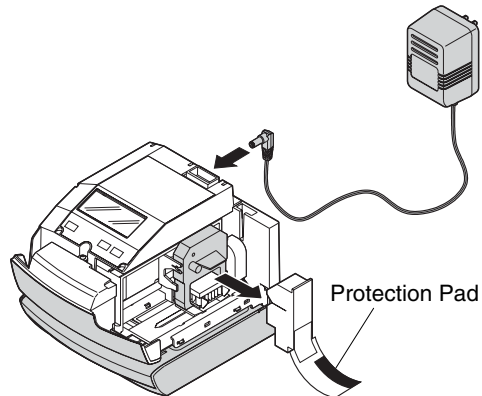

Step 3

Replace the cover and lock.

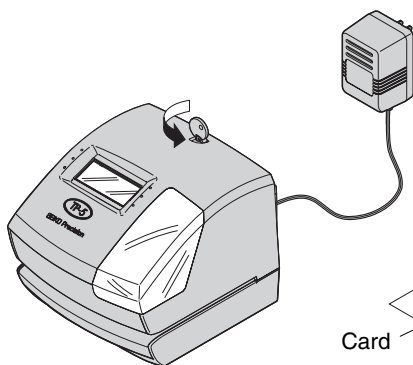

Step 4

Plug the AC adapter into the AC outlet and insert a card.

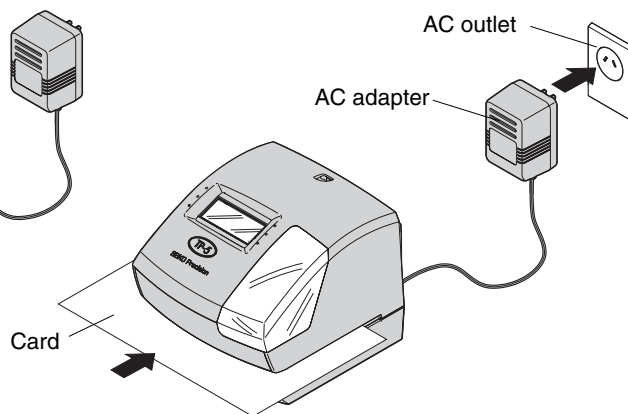

HOW TO PROGRAM THE CLOCK

To enter the program setting mode, you should plug the AC adapter into the AC outlet and remove the cover. Thereafter press the **SELECT** button once. Then the clock goes into the program mode showing the "▲" on the display positioned at the "TIME".

L.C.D.
Reference for programming
'AA BB-CC'

PRINT ORDER

Y=Year	1. M.D.H.Min	10. M.D
M=Month	2. D.M.H.Min	11. DOW.D.M.Y
D=Date	3. M.D.Y.H.Min	12. C.M.D.Y
DOW=Day of the week	4. D.M.Y.H.Min	13. C.D.M.Y
H=Hour	5. Y.M.D.H.Min	14. C.Y.M.D
Min=Minute	6. Y.M.D.H.Min.S	15. M.D.Y.C
S=Second	7. D.H.Min	16. D.M.Y.C
C=Comment	8. DOW.D.H.Min	17. Y.M.D.C
	9. Y.M.D	18. C.D.H.Min

DISPLAY

AA:Sec.	AA:Year	1.12hour
BB:Hour	BB:Month	2.24hour
CC:Min.	CC:Date	

PRINT STYLE

1.2Digits	BB:Hour	1.ZERO	1.RCVD
2.4Digits	1.12hour	Disabled	2.SENT
	2.24hour	2.ZERO	3.IN
		Enabled	4.OUT
CC:Minute			5.CFMD
1.1/60			6.FILED
2.1/100			7.PAID
3.1/20			8.USED
4.1/10			9.FAXED
			10.VOID
			11.ORIGN
			12.APR'D
			13.CMPL'D

LANGUAGE

1. ENGLISH
2. FRENCH
3. SPANISH
4. PORTUGUESE

CONTROL BUTTONS: SELECT, CHANGE, SET

Control buttons

Program modes

Function of 3 control buttons

SELECT: You can select the desired program setting mode by pressing this **SELECT** button. Selected program setting mode is indicated by the "▲" mark on the display.

CHANGE: When you press the **CHANGE** button, you can increment the set value.

SET: You can set the value selected on the display by pressing the **SET** button. Thereafter you press this **SET** button again, you can return the clock to the normal operation mode.

SETTING THE DISPLAY FORMAT

SETTING THE TIME

Example: Change the time from 10:08 to 10:09.

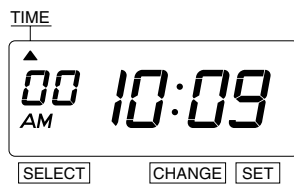
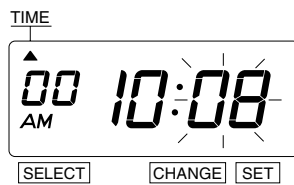
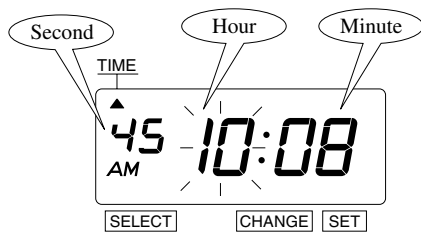

Step 1

Press the **SELECT** button and position the "▲" mark at the "TIME".

At that moment, the "Hour" flashes. (The flashing means it can be changed.)

Change the "Hour".

In case of the example, press the **SET** button because the hour is not to be changed.

At that moment, the flashing changes from "Hour" to "Minute".

Step 2

Change the "Minute".

Press the **CHANGE** button to set at "09", and then press the **SET** button.

At that moment, the "Second" starts to run from "00".

Step 3

After you finish setting the time, press the **SET** button once again.

Now the time setting has been completed. Replace the cover and lock.

IMPORTANT: If you do not complete Step 3, the clock will not print.

SETTING THE DATE

Example: Change the date from October 20, 2005 to October 21, 2005.

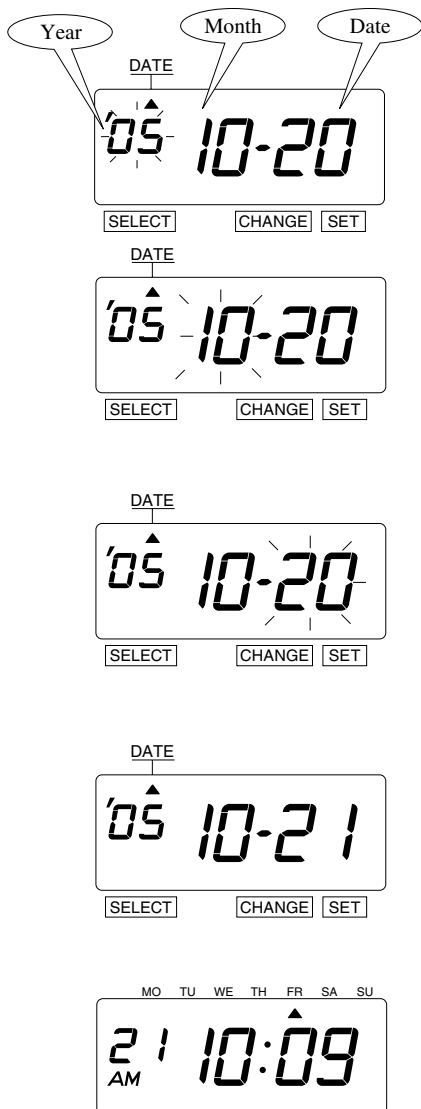

Step 1

Press the **SELECT** button and position the "▲" mark at the "DATE".
At that moment, the "Year" flashes. (The flashing means it can be changed.)

Change the "Year".

In case of the example, press the **SET** button because the year 2005 is not to be changed.

At that moment, the flashing changes from "Year" to "Month".

Step 2

Change the "Month".

In case of the example, press the **SET** button because the month is not to be changed.

At that moment, the flashing changes from "Month" to "Date".

Step 3

Change the "Date".

Press the **CHANGE** button to set at "21", and then press the **SET** button.

Step 4

After you finish setting the date, press the **SET** button once again.
Now the date setting has been completed. Replace the cover and lock.

IMPORTANT: If you do not complete Step 4, the clock will not print.

SETTING THE 12/24 HOUR

Example: Change the hour format to 24 hour.

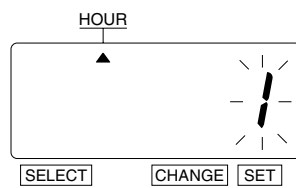

Step 1

Press the **SELECT** button and position the "▲" mark at the "HOUR".

At that moment, the flashing digit indicates "Order Options" of the hour format. (The flashing means it can be changed.)

	Order Options	Display
1.	12 hour	PM 3:00
2.	24 hour	15:00

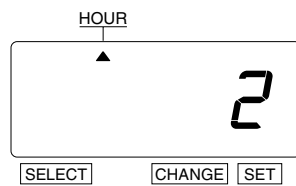

In case of the example, press the **CHANGE** button to set at "2". And then press the **SET** button.

Step 2

After you finish setting the 12/ 24 hour, press the **SET** button once again.

Now the 12/24 hour setting has been completed. Replace the cover and lock.

IMPORTANT: If you do not complete Step 2, the clock will not print.



SETTING THE PRINT ORDER

Example: Change the print order to "Month, Date, Year, Hour, Minute".

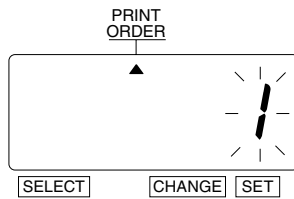

Step 1

Press the **SELECT** button and position the "▲" mark at the "PRINT ORDER".

At that moment, the flashing digits indicate "Order Options" of the print order. (The flashing means it can be changed.)

Y=Year, M=Month, D=Date, DOW=Day of the week, H=Hour, Min=Minute
S=Second, C=Comment

	Order Option	Print Example
1.	M, D, H, Min	JAN 31 AM10:00
2.	D, M, H, Min	31 JAN AM10:00
3.	M, D, Y, H, Min	JAN 31 '06 AM10:00
4.	D, M, Y, H, Min	31 JAN '06 AM10:00
5.	Y, M, D, H, Min	'06 JAN 31 AM10:00
6.	Y, M, D, H, Min, S	'06 JAN 31 AM 10:00:00
7.	D, H, Min	31 AM10:00
8.	DOW, D, H, Min	TU, 31 AM10:00
9.	Y, M, D	'06 JAN 31
10.	M, D	JAN 31
11.	DOW, D, M, Y	TU, 31 JAN '06
12.	C, M, D, Y	SENT JAN 31 '06
13.	C, D, M, Y	SENT 31 JAN '06
14.	C, Y, M, D	SENT '06 JAN 31
15.	M, D, Y, C	JAN 31 '06 SENT
16.	D, M, Y, C	31 JAN '06 SENT
17.	Y, M, D, C	'06 JAN 31 SENT
18.	C, D, H, Min	SENT 31 AM10:00

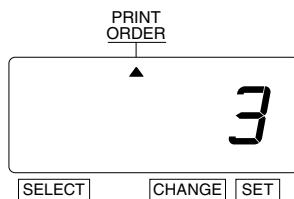

In case of the example, press the **CHANGE** button to set at "3". And then press the **SET** button.

Step 2

After you finish setting the print order, press the **SET** button once again. Now the print order setting has been completed. Replace the cover and lock.

IMPORTANT: If you do not complete Step 2, the clock will not print.



SETTING THE PRINT STYLE

SETTING THE YEAR DIGIT

Example: Change the year imprint to 4 digits.

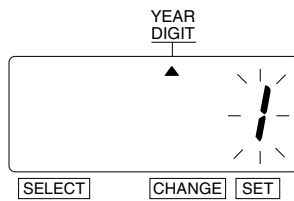

Step 1

Press the **SELECT** button and position the "▲" mark at the "YEAR DIGIT".

At that moment, the flashing digit indicates "Order Options" of the year imprint. (The flashing means it can be changed.)

	Order Options	Print Example
1.	2 Digits	JAN 31 '06 AM10:00
2.	4 Digits	JAN 31 2006 AM10:00

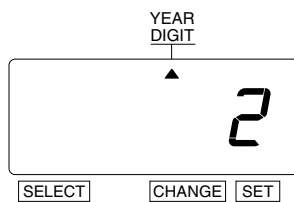

In case of the example, press the **CHANGE** button to set at "2", and then press the **SET** button.

Step 2

After you finish setting the year digit, press the **SET** button once again.

Now the year digit setting has been completed. Replace the cover and lock.



IMPORTANT: If you do not complete Step 2, the clock will not print.

SETTING THE HOUR/MIN.

Example: Change the print style of the "Hour" and "Minute" to 24 hour and 1/100 min.

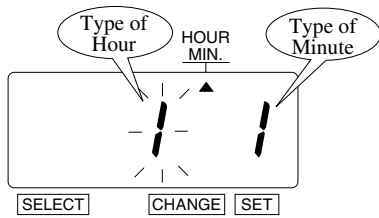

Step 1

Press the **SELECT** button and position the "▲" mark at the "HOUR / MIN".

At that moment, the flashing digit at the left indicates "Order Options" of the print style of the "Hour". (The flashing means it can be changed.)

Change the "Hour".

	Order Options	Print Example
1.	12 Hour	JAN 31 PM3:00
2.	24 Hour	JAN 31 15:00

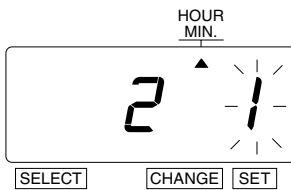

In case of the example, press the **CHANGE** button to set at "2". And then press the **SET** button.

At that moment, the flashing changes from "Hour" to "Minute".

Step 2

Change the "Minute".

	Order Options	Print Example		Order Options	Print Example
1.	1/60 Min.	JAN 31 AM12:10	3.	1/20 Min. (=5/100 Min.)	JAN 31 AM12.15
2.	1/100 Min.	JAN 31 AM12.17	4.	1/10 Min.	JAN 31 AM12.1

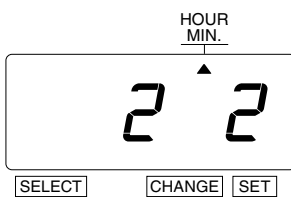

In case of the example, press the **CHANGE** button to set at "2". And then press the **SET** button.

Step 3

After you finish setting the hour/minute, press the **SET** button once again. Now the hour/minute setting has been completed. Replace the cover and lock.

IMPORTANT: If you do not complete Step 3, the clock will not print.



SETTING THE LEADING ZERO

Example: Change the leading zero to "ZERO: Disabled".

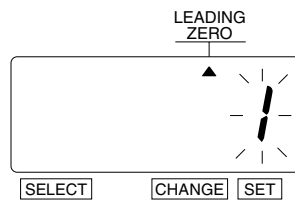

Step 1

Press the **SELECT** button and position the "▲" mark at the "LEADING ZERO". At that moment, the flashing digit indicates "Order Options" of the leading zero.

(The flashing means it can be changed.)

	Order Options	Print Example
1.	ZERO Disabled	JAN 1 PM3:00
2.	ZERO Enabled	JAN 01 PM03:00

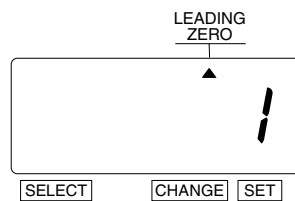

In case of the example, press the **CHANGE** button to set at "1". And then press the **SET** button.

Step 2

After you finish setting the leading zero, press the **SET** button once again.

Now the leading zero setting has been completed. Replace the cover and lock.

IMPORTANT: If you do not complete Step 2, the clock will not print.



SETTING THE COMMENT

Example: Change the comment to "SENT".

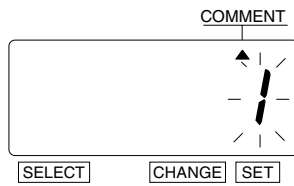

Step 1

Press the **SELECT** button and position the "▲" mark at the "COMMENT".
At that moment, the flashing digits indicate "Order Options" of the comment.
(The flashing means it can be changed.)

	Order Options	Print Example
1.	RCVD	JAN 31 '06 RCVD
2.	SENT	JAN 31 '06 SENT
3.	IN	JAN 31 '06 IN
4.	OUT	JAN 31 '06 OUT
5.	CFMD	JAN 31 '06 CFMD
6.	FILED	JAN 31 '06 FILED
7.	PAID	JAN 31 '06 PAID
8.	USED	JAN 31 '06 USED
9.	FAXED	JAN 31 '06 FAXED
10.	VOID	JAN 31 '06 VOID
11.	ORIGN	JAN 31 '06 ORIGN
12.	APR'D	JAN 31 '06 APR'D
13.	CMPL'D	JAN 31 '06 CMPL'D

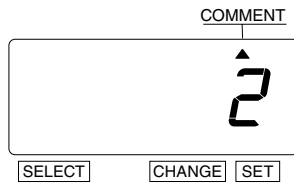

In case of the example, press the **CHANGE** button to set at "2". And then press the **SET** button.



Step 2

After you finish setting the comment, press the **SET** button once again.
Now the comment setting has been completed. Replace the cover and lock.

IMPORTANT: If you do not complete Step 2, the clock will not print.

SETTING THE LANGUAGE

This setting is available if you select "Month," "Day of the week" or "Comment" in previous "PRINT ORDER".

Example: Change the print language into French.

Step 1

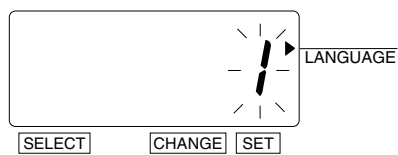

Press the **SELECT** button and position the "▲" mark at the "LANGUAGE".

At that moment, the flashing digit indicates "Order Options" of the print language. (The flashing means it can be changed.)

	Order Options	Print Example
1.	ENGLISH	WE, 28 DEC '05 OUT 31 AM10:00
2.	FRENCH	ME, 28 DEC '05 SORT 31 AM10:00
3.	SPANISH	MI, 28 DIC '05 SAL 31 AM10:00
4.	PORTUGUESE	QA, 28 DEZ '05 SAIDA 31 AM10:00

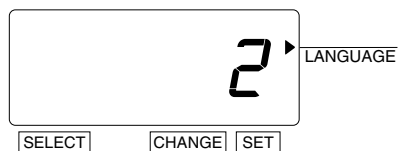

In case of the example, press the **CHANGE** button to set at "2". And then press the **SET** button.

Step 2



After you finish setting the language, press the **SET** button once again.

Now the language setting has been completed. Replace the cover and lock.

IMPORTANT: If you do not complete Step 2, the clock will not print.

SETTING THE PRINT METHOD

Example: Change the print direction to "Left" and the print activation to "Manual".

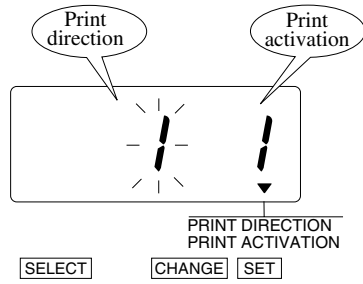

Step 1

Press the **SELECT** button and position the "▲" mark at the "PRINT DIRECTION; PRINT ACTIVATION".

At that moment, the flashing digit at the left indicates "Order Options" of the print direction. (The flashing means it can be changed.)

Change the "Print Direction".

	Order Options
1.	Right
2.	Left

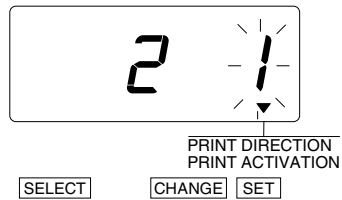

In case of the example, press the **CHANGE** button to set at "2". And then press the **SET** button.

At that moment, the flashing changes from the "Print Direction" to the "Print Activation".

Step 2

Change the "Print Activation".

	Order Options
1.	Automatic
2.	Semi-automatic
3.	Manual

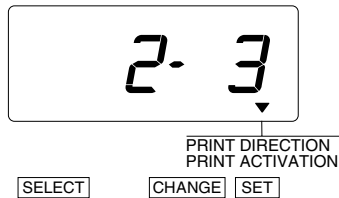

In case of the example, press the **CHANGE** button to set at "3". And then press the **SET** button.

Step 3



After you finish setting the print method, press the **SET** button once again. Now the print method setting has been completed. Replace the cover and lock.

IMPORTANT: If you do not complete Step 3, the clock will not print.

Automatic will allow the clock to print by simply inserting a card or sheet of paper.

Semi-automatic will allow the clock to print by pressing the push bar only when a card or piece of paper is inserted.

Manual will allow the clock to print by pressing the push bar.

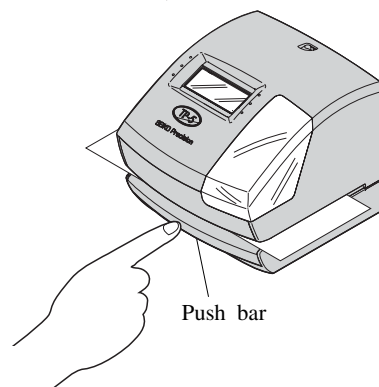

SETTING THE DAYLIGHT SAVING TIME

Example: Start date Sunday, March 26, 2006.

End date Sunday, October 29, 2006.

If you set as the above, **the time clock remembers the start date as the last Sunday of March and the end date as the last Sunday of October.** Once set, the time clock automatically updates the settings every year thereafter. No further manual setting is necessary.

SETTING THE STARTING DATE OF DAYLIGHT SAVING TIME

Example: Daylight saving time starts on Sunday, March 26, 2006.

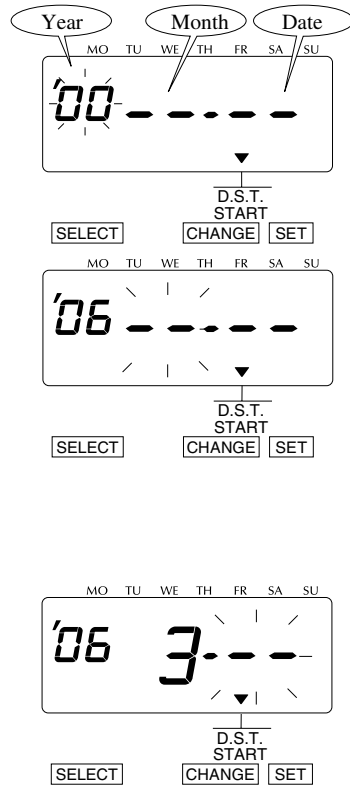

Step 1

Press the **SELECT** button and position the "▲" mark at the "D.S.T. START". At that moment, the "Year" flashes. (The flashing means it can be changed.)

Change the "Year".

In case of the example, press the **CHANGE** button to set at "06". And then press the **SET** button.

At that moment, the flashing changes from "Year" to "Month".

Step 2

Change the "Month".

Press the **CHANGE** button to set at "3". And then press the **SET** button.

At that moment, the flashing changes from "Month" to "Date".

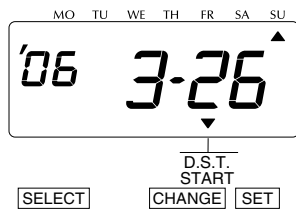

Step 3

Change the "Date".

Press the **CHANGE** button to set at "26".
And then press the **SET** button.



Step 4

After you finish setting the starting date of D.S.T., press the **SET** button once again. Now the starting date of D.S.T. setting has been completed.

Go on to the "SETTING THE ENDING DATE OF DAYLIGHT SAVING TIME".

SETTING THE ENDING DATE OF DAYLIGHT SAVING TIME

Example: Daylight saving time ends on Sunday, October 29, 2006.

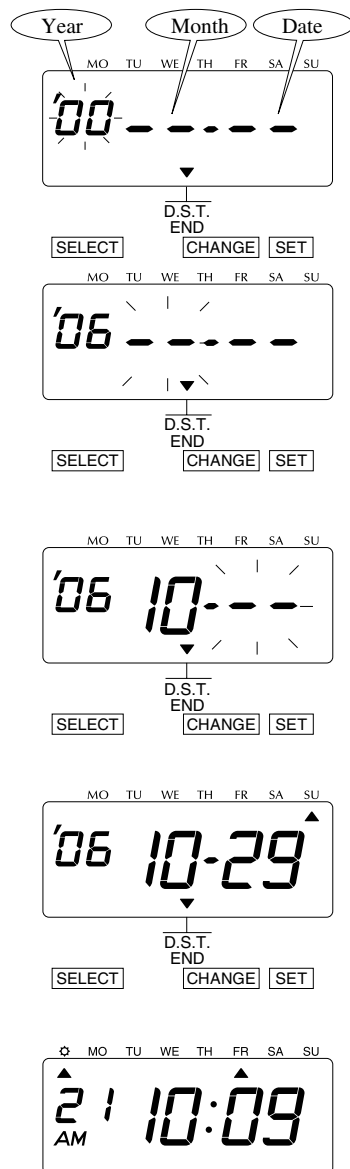

Step 1

Press the **SELECT** button and position the "▲" mark at the "D.S.T. END". At that moment, the "Year" flashes. (The flashing means it can be changed.)

Change the "Year".

In case of the example, press the **CHANGE** button to set at "06". And then press the **SET** button.

At that moment, the flashing changes from "Year" to "Month".

Step 2

Change the "Month".

Press the **CHANGE** button to set at "10". And then press the **SET** button.

At that moment, the flashing changes from "Month" to "Date".

Step 3

Change the "Date".

Press the **CHANGE** button to set at "29". And then press the **SET** button.

Step 4

After you finish setting the ending date of D.S.T., press the **SET** button once again. Now the ending date of D.S.T. setting has been completed. Replace the cover and lock.

IMPORTANT: If you do not complete Step 4, the clock will not print.

DELETING THE DAYLIGHT SAVING TIME SETTING

To delete and cancel the daylight saving time setting, change the display of "Month" of the starting setting to " -- ".

Example: Change March 26, 2006 of "D.S.T. START" and delete daylight saving time setting.

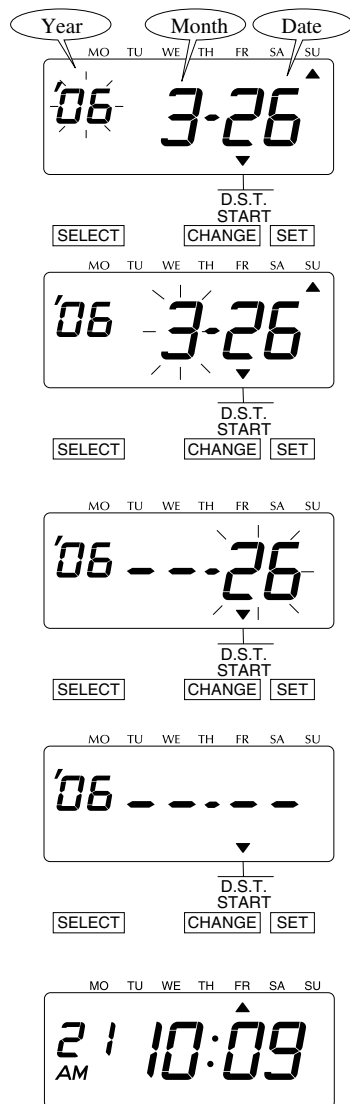

Step 1

Press the **SELECT** button and position the "▲" mark at the "D.S.T. START".

At that moment, the "Year" flashes. (The flashing means it can be changed.)

Next, press the **SET** button. At that moment, the flashing changes from "Year" to "Month".

Step 2

Press the **CHANGE** button to set at " -- ". And then press the **SET** button.

At that moment, the flashing changes from "Month" to "Date".

Step 3

Press the **SET** button again. At that moment, the flashing changes from "26" to " -- ".

Step 4

Press the **SET** button once again. Now the D.S.T. deleting has been completed. Replace the cover and lock.

IMPORTANT: If you do not complete Step 4, the clock will not print.

SETTING THE PASSWORD

When the password is set, you are asked to enter it. If the password you entered does not coincide with the setting, you cannot change the setting values.

You may set a password by any 4-digit number from 0001 to 9998.

Note a number "0000" and "9999" cannot be used as a password.

REGISTERING THE PASSWORD

Example: Set the password "1234".

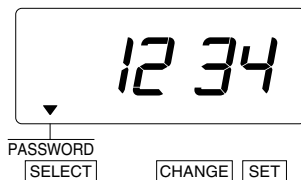
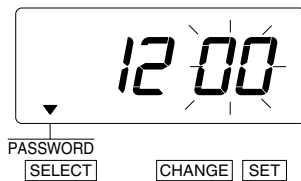
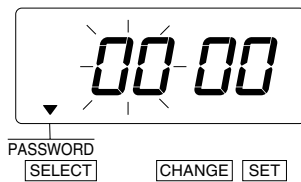

Step 1

Press the **SELECT** button and position the "▲" mark at the "PASSWORD".

At that moment, first two digits flash. (The flashing means it can be changed.)

In case of the example, press the **CHANGE** button to set at "12". And then press the **SET** button.

At that moment, the flashing changes to last two digits.

Step 2

In case of the example, press the **CHANGE** button to set at "34". And then press the **SET** button.

Step 3

After you finish registering the password, press the **SET** button once again.

Now the password registering has been completed. Replace the cover and lock.

IMPORTANT: If you do not complete Step 3, the clock will not print.

HOW TO CHANGE SETTING WHEN THE PASSWORD IS SET

Once the password is set, you have to enter the password for changing any setting. "99 99" will be displayed when you press the **SELECT** button before entering.

Example: Password "1234".

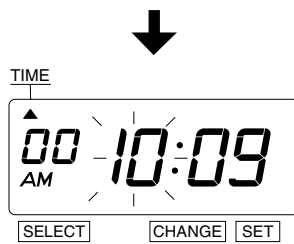
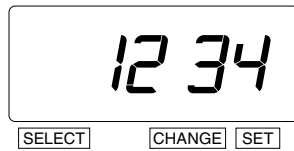
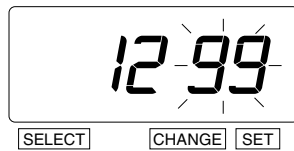
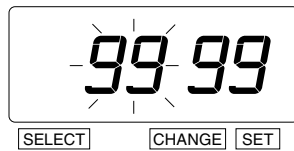

Step 1

Press the **SELECT** button, at that moment "99 99" is displayed and first two digits flashes. (The flashing means it can be changed.)

In the example, press the **CHANGE** button to set at "12". And then press the **SET** button.

At that moment, the flashing changes to last two digits.

Step 2

In case of the example, press the **CHANGE** button to set at "34". And then press the **SET** button.

At that moment, the "▲" mark indicates the "TIME".

Step 3

Select desired setting mode by pressing the **SELECT** button.

Then make settings as explained.

CANCELING THE PASSWORD

The code "00 00" must be entered to cancel the password.

Example: Cancel the password "1234".

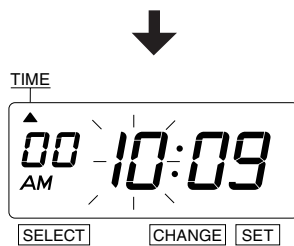
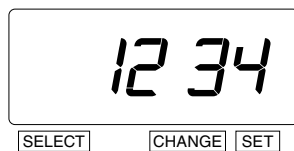
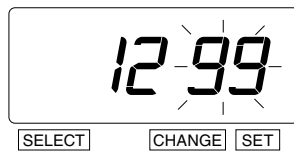
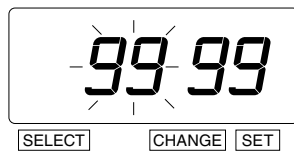

Step 1

Press the **SELECT** button, at that moment "99 99" is displayed and first two digits flashes. (The flashing means it can be changed.)

In case of the example, press the **CHANGE** button to set at "12". And then press the **SET** button.

At that moment, the flashing changes to last two digits.

Step 2

In case of the example, press the **CHANGE** button to set at "34". And then press the **SET** button.

At that moment, the "▲" mark indicates the "TIME".



PASSWORD
SELECT CHANGE SET



PASSWORD
SELECT CHANGE SET



PASSWORD
SELECT CHANGE SET



Step 3

Press the **SELECT** button and position the "▲" mark at the "PASSWORD".

At that moment, first two digits "12" flashes. (The flashing means it can be changed.)

Press the **CHANGE** button to set at "00". And then press the **SET** button.

At that moment, the flashing changes to last two digits "34".

Step 4

Press the **CHANGE** button to set at "00". And then press the **SET** button.

Step 5

After you finish canceling the password, press the **SET** button once again.

Now the password canceling has been completed. Replace the cover and lock.

IMPORTANT: If you do not complete Step 5, the clock will not print.

RESETTING

To return all setting to the factory defaults, push the reset switch with a pointed implement.

NOTICE: All your custom settings will be deleted and will revert to the factory defaults when the reset switch is pushed. To make new settings, please refer to "SETTING".

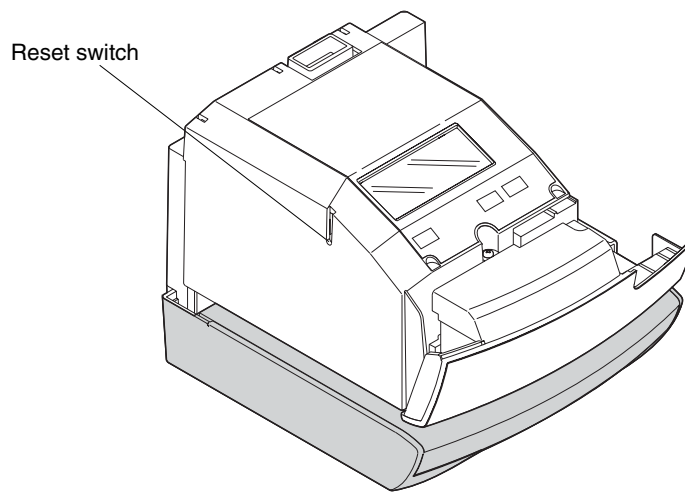

WALL MOUNTING

Caution: The supplied screws are intended for use on a thick wooden wall or wooden column. Do not use them on any other materials. The time clock may come off if used on other materials.

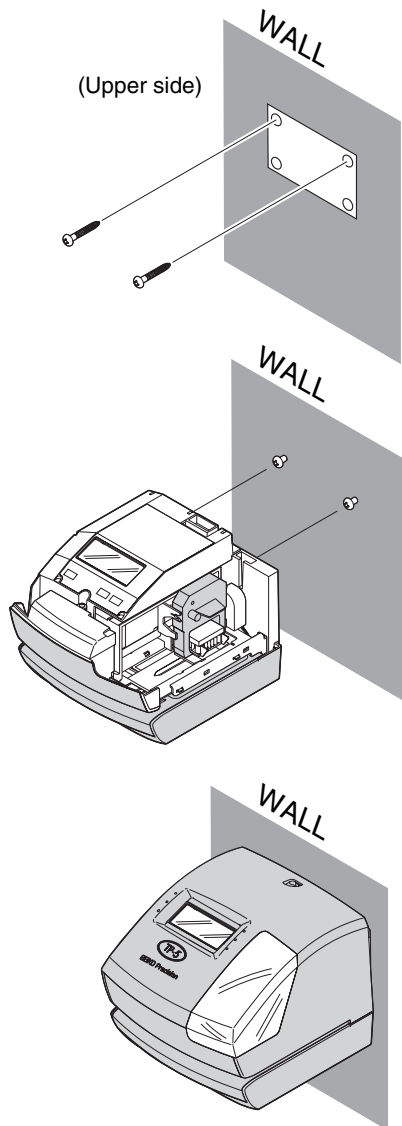

Step 1

Install the supplied wall-mount screws into a wall by using the template. Be sure to keep about 6 mm of the screw head away from the wall.

Step 2

Unlock the key and remove the cover. And then hang it on the wall.

Step 3

Replace the cover and lock.

REPLACING THE RIBBON CASSETTE

CAUTION: Be sure to pull out AC cord from AC outlet before opening a cover in order to replace a ribbon cassette.

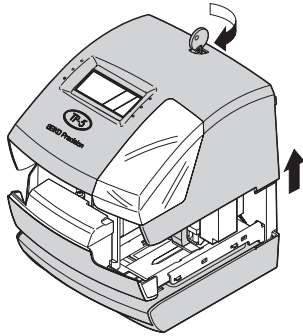

Step 1

Unlock the key and remove the cover.

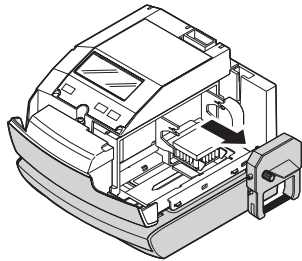

Step 2

Pick up the cassette and remove it.

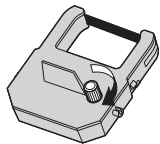

Step 3

Turn the knob of the new cassette in the direction of the arrow to tighten the ribbon.

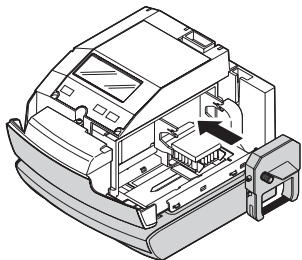

Step 4

Place the cassette inside the time clock as shown in the figure. Keep on pushing in the cassette until the clasps at both sides catch and you hear a "pop" sound. If it is difficult to insert the cassette, try it while turning the knob.

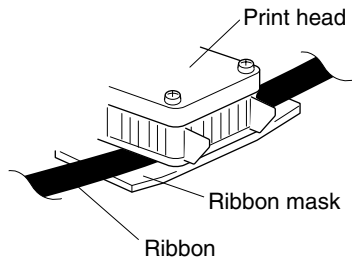

NOTICE: Install the cassette so that the ribbon is between the print head and the ribbon mask. Printing will not come out properly if the ribbon is placed behind the ribbon mask.

Step 5

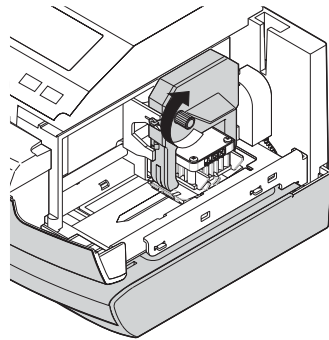

Step 6

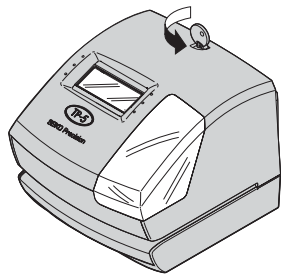

TROUBLESHOOTING

ERROR No. APPEARS

Refer to the following list for proper operation.

Error No.	Error contents	Action
E-00	CPU error	Contact the store from whom you bought the Time Clock.
E-01	The remaining life of lithium battery for memory back-up is short.	
E-05	The card is not inserted in the clock properly.	Correctly insert the card.
E-30	Cannot print. The printer motor or home position sensor is not normal.	Make sure that the ribbon cassette is correctly inserted in place.
E-38	Cannot print. The print head motor or the sensor does not operate properly.	Press the push bar.
E-40	Incorrect password	Enter the correct password again.
E-41	D.S.T. setting mistake	Make sure the correct starting and ending date of daylight saving time and enter again.
E-49	Setting data you entered is not usable.	Refer to your owner's manual on the page related to the item you want to set and enter again correct setting data.

OTHER FAILURES

- **The time clock does not operate.**

Ensure the AC adapter is properly plugged into the AC outlet.

- **The time clock does not print.**

Ensure the ribbon is installed correctly.

- **The card is jammed.**

Press the push bar and try to pull out the card at the same time.

SPECIFICATIONS

Clock accuracy	Monthly accuracy ± 15 sec. (at ordinary temperatures)
Calendar	Year up to 2099. Automatically adjusted to leap years, 31-day months and months with thirty or fewer days, and the days of the week.
Printing system	Dot matrix imprint
Power failure compensation	Five years of cumulative power failure hours after the date of shipment.
Operating environment:	Temperature: -5° to 45° C, $+23^{\circ}$ to 113° F Humidity: 20 to 80%, no condensation The unit operates normally at temperatures of 5° C or below, but the print density, reaction of the liquid crystal display, and the number of prints at power failure are inferior to those at normal temperature operation.
Dimension	160(w) x 184(d) x 144(h) mm, 6.3"(w) x 7.2"(d) x 5.7"(h)
Weight	Approx. 1.4 kg. (2.0 kg with AC adapter)
Power consumption	240VAC $\pm 10\%$, 50Hz, 0.2A
Rating of AC adapter	I/P AC 240V/50Hz O/P AC 15.0V 1300mA

NOTICE: Use only the supplied AC adapter.

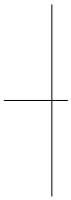
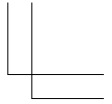
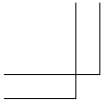

SEIKO PRECISION INC.

Q7170-6120

