

Syncroline

Master Clock System

Specifications

General

The work covered by this section of the specification includes the supply, installation, testing, commissioning and defects liability maintenance of all the equipment necessary to provide a Master Clock System.

Provide a new GPS based Master Clock System such as Syncroline Master Clock System. The entire clock system shall be of Syncroline Analog Clock, Syncroline Digital Clock or equivalent.

Clocks to be provided shall be of the type and location as described in the Room Data Sheets and as shown on the drawings.

The system generally shall comprise the following elements:-

- High accuracy GPS based Master Clock
- Compatible slave clocks (Analogue or Digital)
- All interconnecting power, control cabling and connections
- Line Boosters where required

Master Clock (Single Building Applications)

Supply and install a GPS based Master Clock suitable for wall mounting. This shall be a Syncroline Model KT3000GPS, or equivalent. The Master Clock will operate on a dedicated 240V 50Hz power outlet located within 1 meter of the Master Clock.

Internal automatically rechargeable batteries shall maintain memory of the Master Clock for a period in excess of 160 hours of timekeeping.

Master Clock to be located within 4.5 meters of a north facing window or rooftop, to enable the mounting of the GPS antenna, the GPS antenna shall be provided with a 5 meter lead with provision for a 10 meter extension.

Output voltage 1.3 amps at 24volts in syncroline signal format.

Master Clock (Multiple Building Applications)

Supply and install a Master Clock Controller and GPS Timeserver suitable for wall mounting. This shall be a Syncroline Model KT2050 and KT2000 or equivalent. They each will operate on a dedicated 240V 50Hz power outlet and interconnect via a Cat5 connection located within 1meter.

Each building will require a KT2050 Clock Controller networked back to the KT2000 GPS Timeserver.

Internal automatically rechargeable batteries shall maintain memory of the Master Clock Controller for a period in excess of 160 hours of timekeeping.

GPS Timeserver to be located within 4.5 meters of a north facing window or rooftop, to enable the mounting of the GPS antenna, the GPS antenna shall be provided with a 5 meter lead with provision for a 10 meter extension.

Clock Controller output voltage 1.3 amps at 24volts in syncroline signal format.

Analogue Slave Clocks

Analogue slave clocks shall be of the Syncroline model SL300 or equivalent.

They shall receive 24VDC from the Master Clock and automatically synchronize, be silent in operation and capable of connection to the Master Clock System as detailed. The clocks shall have in-built checking mechanisms which relate to the real time of the Master Control.

Their power consumption shall not exceed 20mA continuous. Diameter shall be 300mm. Dials shall be white with black Arabic numbers or as detailed by the architect. Hour and minute hands shall be black taper and the sweep second hand shall be red. The total mechanism and dial shall be housed in an anodized aluminum case and covered with an acrylic lens to exclude dust or lint, also for the protection of the dial and hands and shall meet the requirements of food processing areas.

Each clock shall incorporate a flexible line cord of .75mm² red/black fig8.

Cabling at each clock point shall be terminated in a Krontek SL10 recessed clock outlet.

Mounting arrangements for surface mount single dial, ceiling suspension double dial and wall suspension double dial shall be provided as detailed on the drawings.

Digital Slave Clocks

Digital slave clocks shall be of the Syncroline models SL455, SL160S or SL160C. They shall receive 24VDC from the Master Clock and automatically synchronize, be silent in operation and capable of connection to the Master Clock System as detailed. The clocks shall have in-built checking mechanisms which relate to the real time of the Master Control.

The clock power consumption shall not exceed that specified for each model listed below.

- SL455, 100mA continuous.
- SL160S, 110mA continuous.
- SL160C, 330mA continuous.

The clock must have 4-Digit / 6-Digit Red 7 segment LEDs, (depending on the model) a minimum numeral viewing distance of 50 meters.

The clock shall not require any battery or local power supply.

Each clock shall incorporate a flexible line cord of .75mm² red/black fig8.

Cabling at each clock point shall be terminated in a Krontek SL10 recessed clock outlet.

Mounting arrangements for surface mount single dial, ceiling suspension double dial and wall suspension double dial shall be provided as detailed on the drawings.

Master Clock Cabling

Provide a 240VAC supply to Master Clock on dedicated circuit. Cable from Master Clock to Syncroline slave clocks shall be 1 x Fig8 1.5mm² or equivalent terminating in a Krontek SL10 recessed clock outlet. Wiring shall loop in loop out from clock point to clock point.

Line Boosters

Where the total load of slave clocks exceeds 1200Ma or where excessive distance is covered, a Krontek Model SL410 Line Booster will be required to transmit the signal at the correct voltage.

The Line Booster will require a local dedicated 240V AC supply.

Output voltage 2.5 amps at 24volts in syncroline signal format.

Hospital Theatre Clock & Timer (Digital)

The theatre timer must have both 'real time' digital clock connected to the Master Clock (via fig8 cabling) and a digital interval timer with twenty-four hour elapsed time.

The clock shall be completed with a timer control panel. The timer control panel must have a pushbutton and LED indicator for the following operation:

- Start/Stop (Pushbutton) Green, Start timer counter
- Reset (Pushbutton) Red, Reset to zero
- On/Off (Pushbutton) Blue, Turn timer on and off

The twenty-four hour elapsed interval timer shall have hours, minutes and seconds.

The clock and the timer shall have red 7 segment LED displays

The Clock and Timer unit will be recessed into the wall with a stainless steel escutcheon.

The timer control panel shall be flush mounted to the wall and mounted on a one-gang switch box.

Layout Examples

The diagram below shows a typical single building site (non network installation); in this case a KT3000GPS master Clock is used and mounted within 5 – 10 meters of the exterior for antenna cabling.

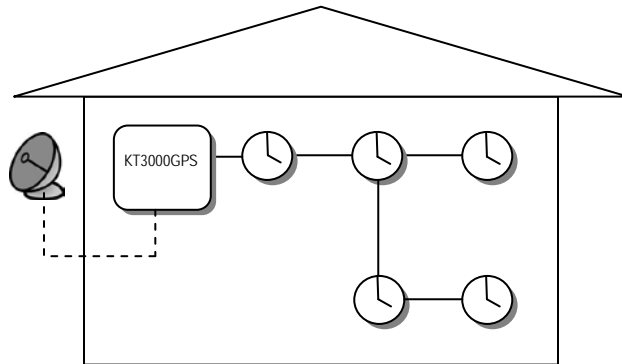

The diagram below shows a multi-building site; in this case a KT2050 Clock Controller & KT2000 GPS Timeserver is used in building A. Both units are patched to existing Cat5 Network and communicate via TCP/IP.

In building B another KT2050 Clock Controller is used and patched to existing Cat5 network and via TCP/IP communicates to the KT2000 GPS Timeserver in building A.

For any subsequent buildings a KT2050 Clock Controller connected to the network would be required.

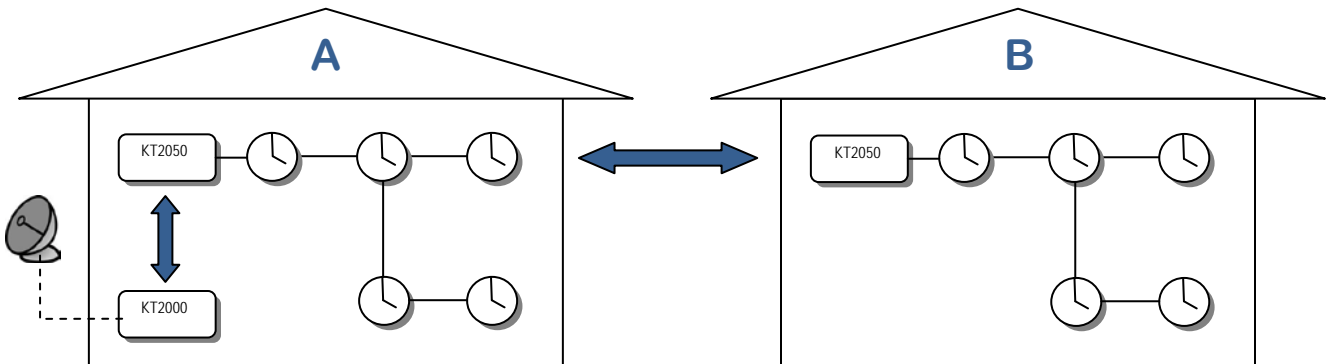

Model Number	Dimensions	Max Current Loading	Current Draw	Power Requirements
KT3000GPS	H88mm, W160mm, D50mm	1300mA	N/A	240v GPO
KT2050	H57mm, W120mm, D27mm	1300mA	N/A	240v GPO
KT2000	H57mm, W85mm, D27mm	N/A	N/A	240v GPO
SL410	H210mm, W140mm, D100mm	2500mA	N/A	240v GPO
SL300	Ø300mm D54mm	N/A	20mA	N/A
SL455	H100mm, W250mm, D58mm (top) D48mm (bottom) 55mm High Digits	N/A	100mA	N/A
SL160S	H135mm, W398mm, D90mm (top) D78mm (bottom) Hour / Minute digits 65mm Seconds / AM/PM digits 50mm	N/A	110mA	N/A
SL160C	H215mm, W398mm, D90mm (top) D70mm (bottom) Hour / Minute digits 65mm Seconds / Month digits 50mm Alpha characters 50/35mm	N/A	330mA	N/A
Dual Theatre Timer	H340mm, W452mm, D45mm Cut-out: H270mm, W380mm	N/A	330mA	N/A

